

.....  
Date May 9, 2016 .....

**APPROVING AND ACCEPTING A PARTIAL ASSIGNMENT OF AN EXISTING SANITARY SEWER EASEMENT ACROSS PROPERTY LOCATED AT 6222 GRAND AVENUE FROM THE CITY OF WEST DES MOINES, IOWA, FOR THE CITY OF WEST DES MOINES' GRAND AVENUE SIPHON REPLACEMENT PROJECT**

**WHEREAS**, the City of West Des Moines, Iowa is replacing an existing sanitary sewer located within the City of Des Moines, Iowa ("Des Moines") and has requested that Des Moines acquire and maintain a portion of said sanitary sewer lying within Des Moines after construction is completed; and

**WHEREAS**, Des Moines' Public Works Department has reviewed the above request and has agreed to accept a portion of the above sanitary sewer lying within Des Moines.

**NOW, THEREFORE, BE IT RESOLVED** by the City Council of the City of Des Moines, Iowa, that the following document conveying a portion of an existing sanitary sewer easement interest to the City of Des Moines, Iowa, recommended for approval and acceptance by the Public Works Department and on file in the office of the City Clerk, be and are hereby approved and accepted as follows:

Grantor:	City of West Des Moines, Iowa
Property Location:	6222 Grand Avenue, Des Moines, Iowa 50312
Document Type:	Partial Assignment of Sanitary Sewer Easement
Consideration:	\$1.00 (Plus Closing Costs)

That the Finance Director is authorized and directed to issue checks to pay any costs certified by the Legal Department and the Engineering Department, and the Real Estate Division Manager is authorized and directed to obtain the checks, if any, needed to carry out this transaction and to deliver them to the payee(s).

That the Real Estate Division of the Engineering Department is directed to obtain the Legal Department's review and approval of all closing documents prior to closing.

That the City Clerk is hereby authorized and directed to endorse upon the Partial Assignment of Sanitary Sewer Easement the approval and acceptance of this Council; the Mayor is authorized and directed to sign the Partial Assignment of Sanitary Sewer Easement and all necessary real estate documents associated with this acquisition; and the City Clerk is further authorized and directed to deliver the aforementioned documents to the Real Estate Division Manager, who shall proceed to closing in accordance with standard real estate practices.



Roll Call Number

Agenda Item Number

12

Date May 9, 2016

Moved by \_\_\_\_\_ to adopt.

APPROVED AS TO FORM:

*Lisa A. Wieland*  
Lisa A. Wieland, Assistant City Attorney

*rw*

COUNCIL ACTION	YEAS	NAYS	PASS	ABSENT
COWNIE				
COLEMAN				
GATTO				
GRAY				
HENSLEY				
MOORE				
WESTERGAARD				
TOTAL				
MOTION CARRIED			APPROVED	
			Mayor	

I, Diane Rauh, City Clerk of said City hereby certify that at a meeting of the City Council of said City of Des Moines, held on the above date, among other proceedings the above was adopted.

IN WITNESS WHEREOF, I have hereunto set my hand and affixed my seal the day and year first above written.

\_\_\_\_\_  
City Clerk

EXHIBIT A-2

SOUTH ROW LINE OF GRAND AVE FROM 1949 & NORTH LINE OF LOT 1

62nd St

Grand Ave

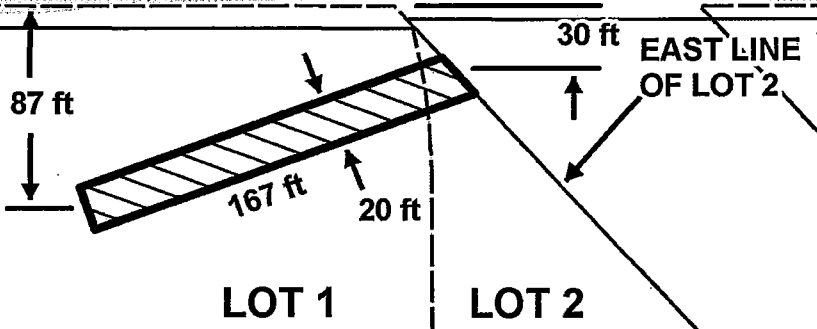

LOT 1

LOT 2

MURROWDALE PLAT NO 2

63rd St

Legend

 New City of Des Moines Easement

